



FUJI
ELECTRIC

SPLIT TYPE
AIR CONDITIONER

CASSETTE type (50Hz)

SERVICE
MANUAL

Models	Indoor unit	Outdoor unit
	RCW-25CA	RO-25A
	RCW-30CA	RO-30A

C O N T E N T S

SPECIFICATIONS 1
 OUTLINE AND DIMENSIONS 2
 CIRCUIT DIAGRAM 4
 REFRIGERANT SYSTEM DIAGRAM 6
 INDOOR PRINTED CIRCUIT BOARD CIRCUIT DIAGRAM 7
 INDOOR P.C. BOARD LAYOUTS 8
 DISASSEMBLY ILLUSTRATION 10
 PARTS LIST 21



Большая библиотека технической документации

<https://splitsystema48.ru/instrukcii-po-ekspluatácii-kondicionerov.html>

каталоги, инструкции, сервисные мануалы, схемы.

S P E C I F I C A T I O N S

TYPE	COOLING	
INDOOR UNIT	RCW-25CA	RCW-30CA
OUTDOOR UNIT	RO-25A	RO-30A
COOLING CAPACITY (kW)	7.00 - 7.10	8.60 - 8.80

ELECTRICAL DATA

POWER SOURCE	220 - 240V 50Hz	
RUNNING CURRENT (A)	12.8 - 13.2	15.8 - 16.3
INPUT WATTS (kW)	2.64 - 2.77	3.30 - 3.40
E.E.R. (kW/kW)	2.65 - 2.56	2.61 - 2.59
STARTING CURRENT (A)	82	80
MOISTURE REMOVAL (ℓ/hr)	2.5	4.0

COMPRESSOR

TYPE	Hermetic type, 2 pole, Single phase, Induction motor	
CODE	AWG 5532EXC	H23A42QABKA
REFRIGERANT R-22 (g)	2,000	2,650

FAN SPEED

INDOOR UNIT	HI-SPEED (r.p.m.)	490	540
	MED-SPEED (r.p.m.)	430	480
	LO-SPEED (r.p.m.)	360	390
OUTDOOR UNIT	(r.p.m.)	720	730

AIR FLOW

INDOOR UNIT	(m³/h)	1,100	1,200
OUTDOOR UNIT		3,000	3,320

DIMENSIONS

INDOOR UNIT	H x W x D (mm)	246 x 830 x 830	
GRILLE		30 x 940 x 940	
OUTDOOR UNIT		700 x 900 x 350	900 x 900 x 350

WEIGHT

INDOOR UNIT	NET / GROSS (kg)	34 / 44	
OUTDOOR UNIT		67 / 77	85 / 97

MAX PIPE LENGTH/HEIGHT (m)	25 / 15	30 / 15
REMOTE CONTROLLER TYPE	WIRELESS	

REFRIGERANT CHARGE

MODELS		PIPE LENGTH							Additional refrigerant
		5 m (16 ft)	7.5 m (25 ft)	10 m (33 ft)	15 m (49 ft)	20 m (66 ft)	25 m (82 ft)	30 m (98 ft)	
FULL CHARGE AMOUNT	RCW-25CA	2,000 g (70.5 oz)	2,030 g (71.6 oz)	2,060 g (72.7 oz)	2,120 g (74.8 oz)	2,180 g (76.9 oz)	2,240 g (79.0 oz)	—	12 g/m (0.4 oz / 3.3 ft)
	RCW-30CA	—	2,650 g (93.5 oz)	2,693 g (95.0 oz)	2,778 g (98.0 oz)	2,863 g (101.0 oz)	2,948 g (104.0 oz)	3,033 g (107.0 oz)	17 g/m (0.6 oz / 3.3 ft)

OUTLINE AND DIMENSIONS

Models : RCW-25CA
RCW-30CA

Unit : (mm)

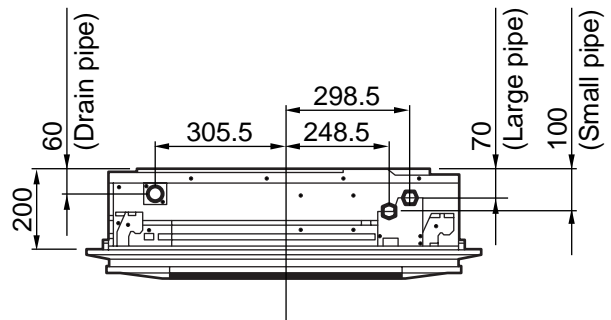
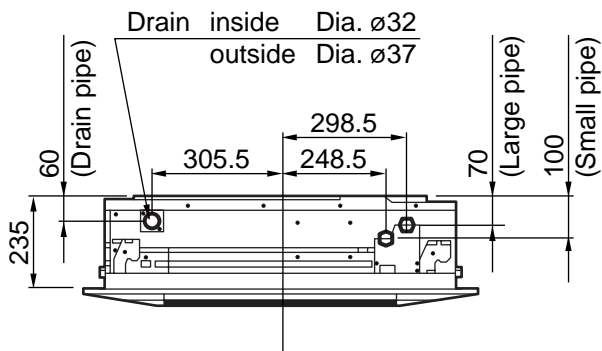
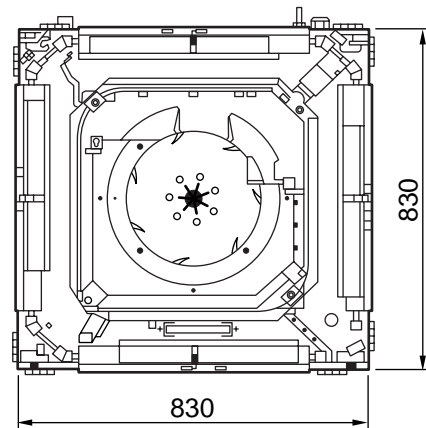
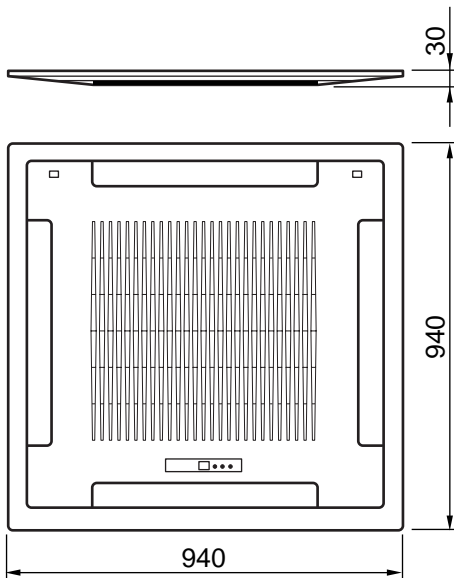

Unit : (mm)

Model : RO-25A

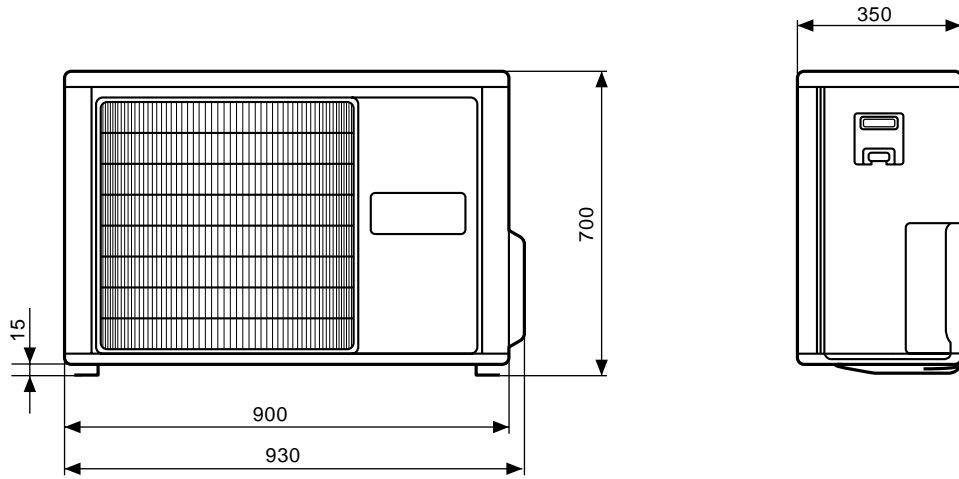

Model : RO-30A

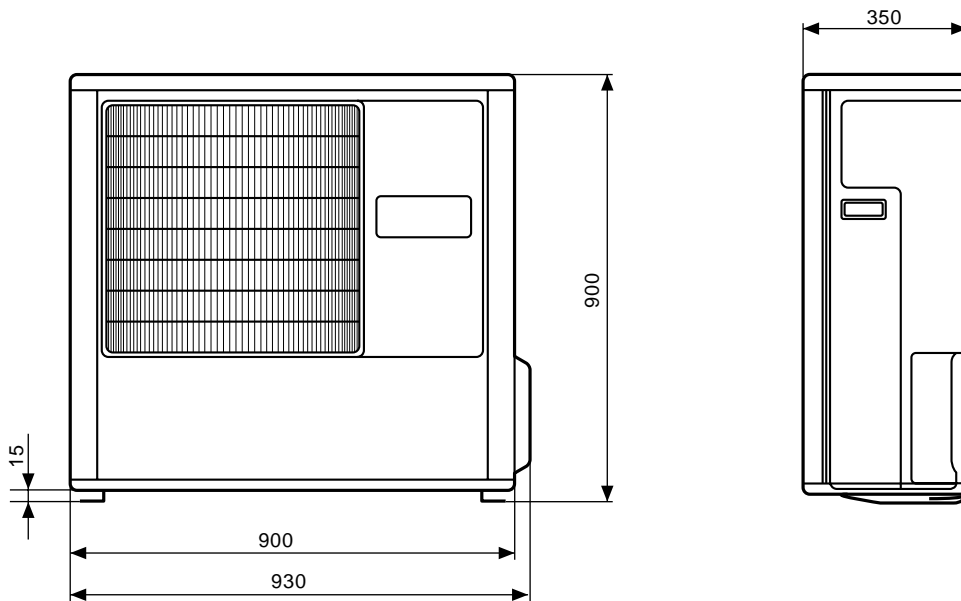

CIRCUIT DIAGRAM

Models : RCW-25CA
RCW-30CA

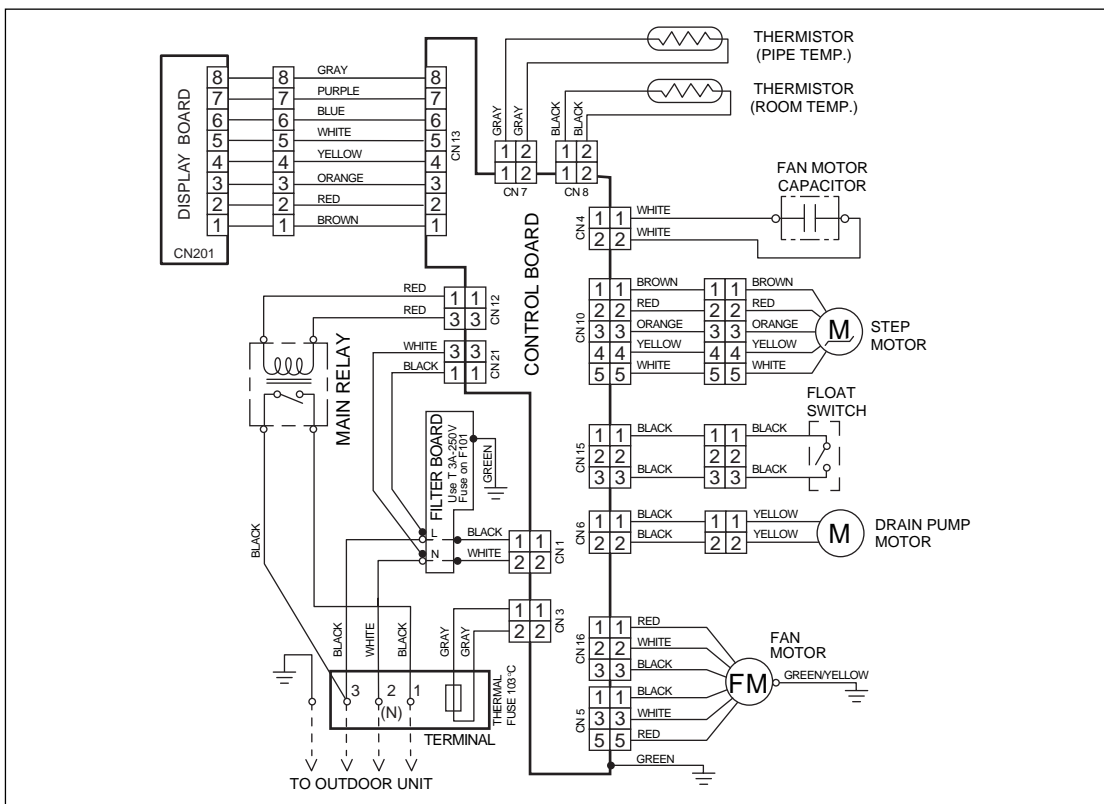

Model : RO-25A

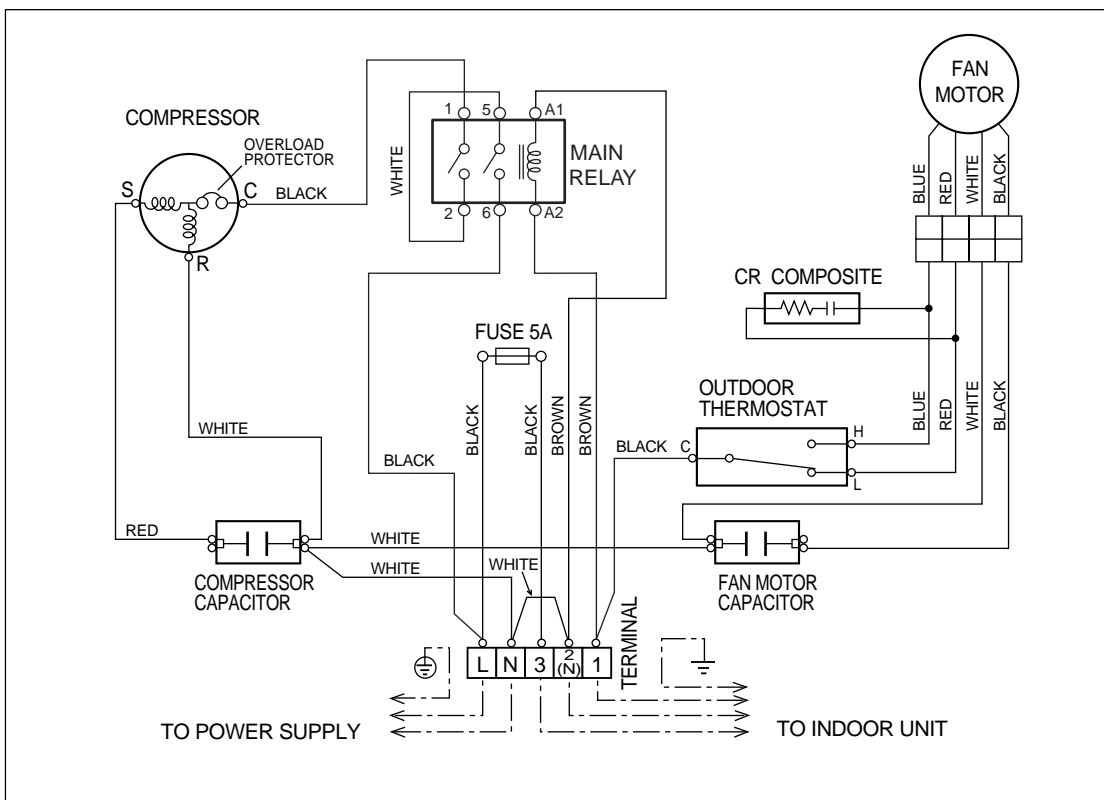

Model :RO-30A

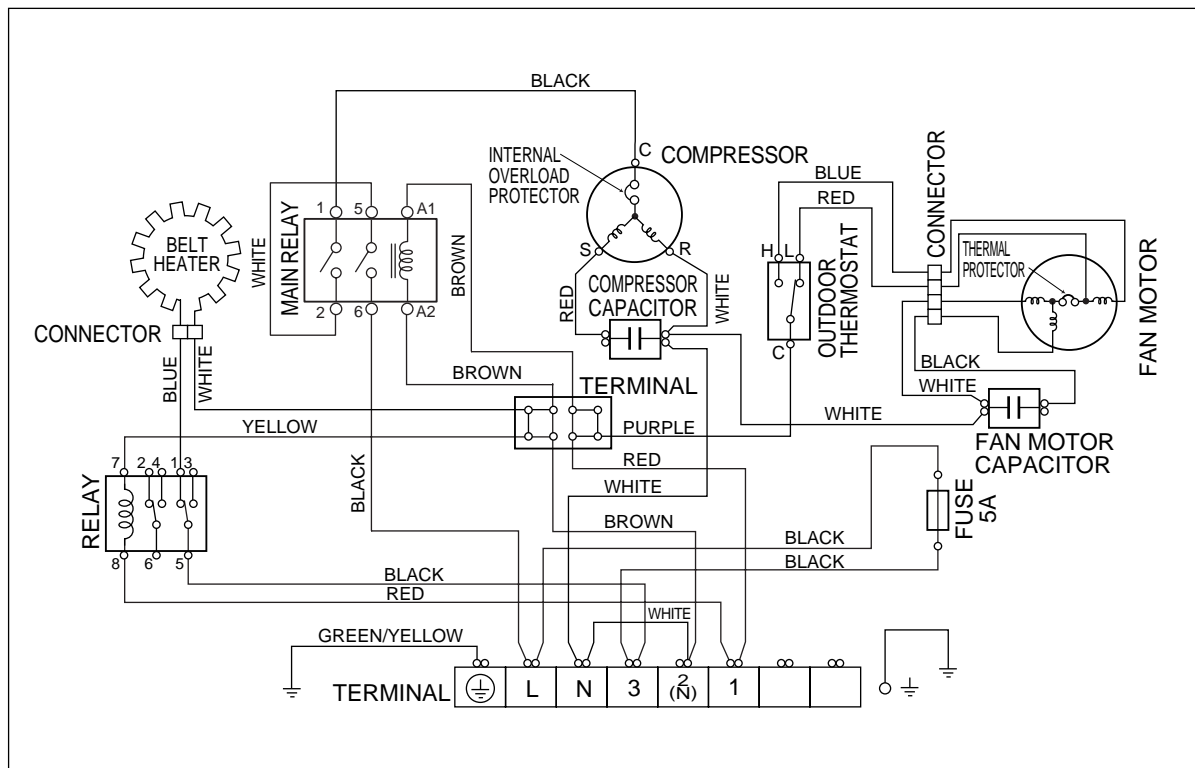

REFRIGERANT SYSTEM DIAGRAM

Models : RCW-25CA / RO-25A

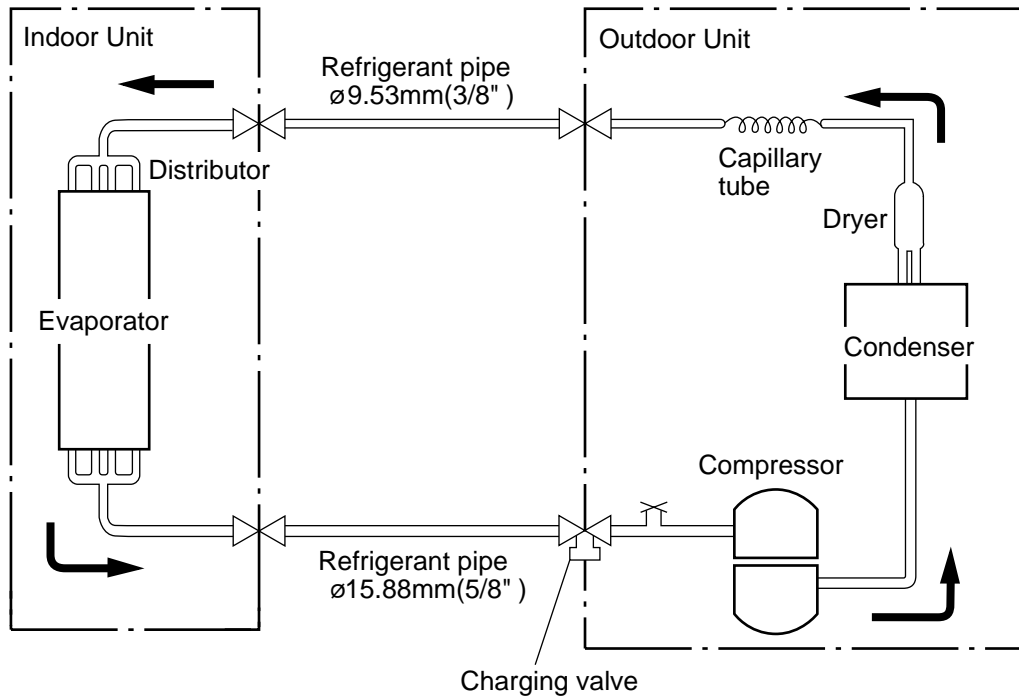

Models : RCW-30CA / RO-30A

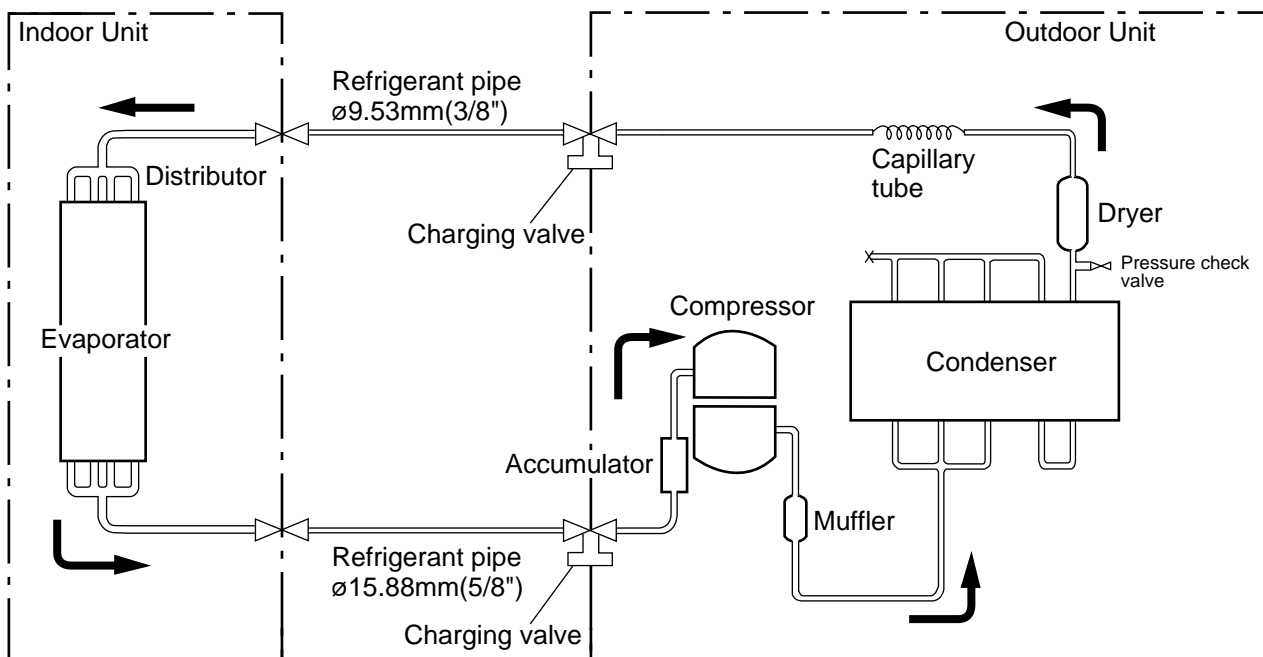

→ Cooling

⊗ : Flare coupling

INDOOR PRINTED CIRCUIT BOARD CIRCUIT DIAGRAM

Models : RCW-25CA
RCW-30CA

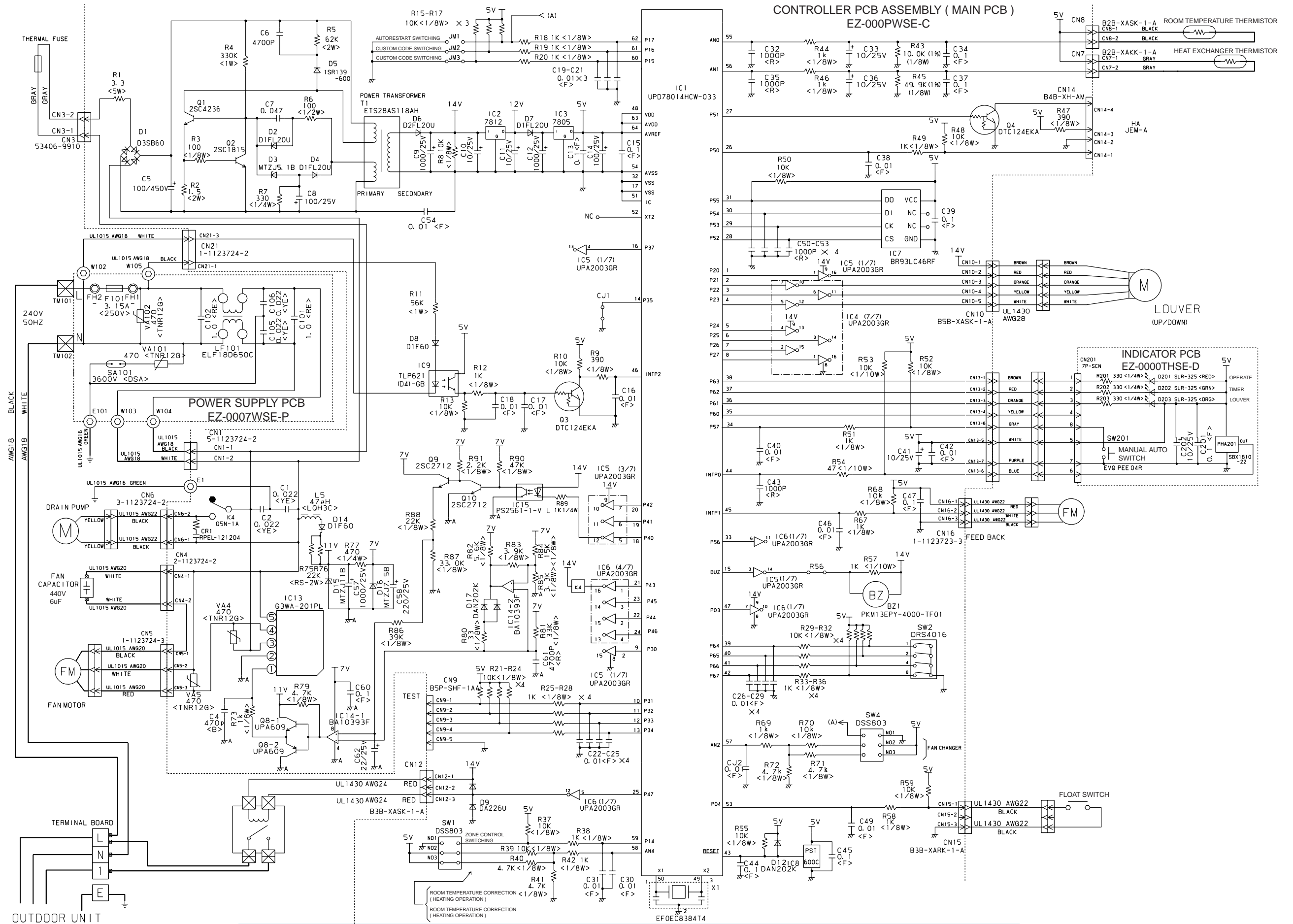

INDOOR P.C. BOARD LAYOUTS

CONTROLLER PCB ASSEMBLY (MAIN PCB)

(Viewed from the component side)

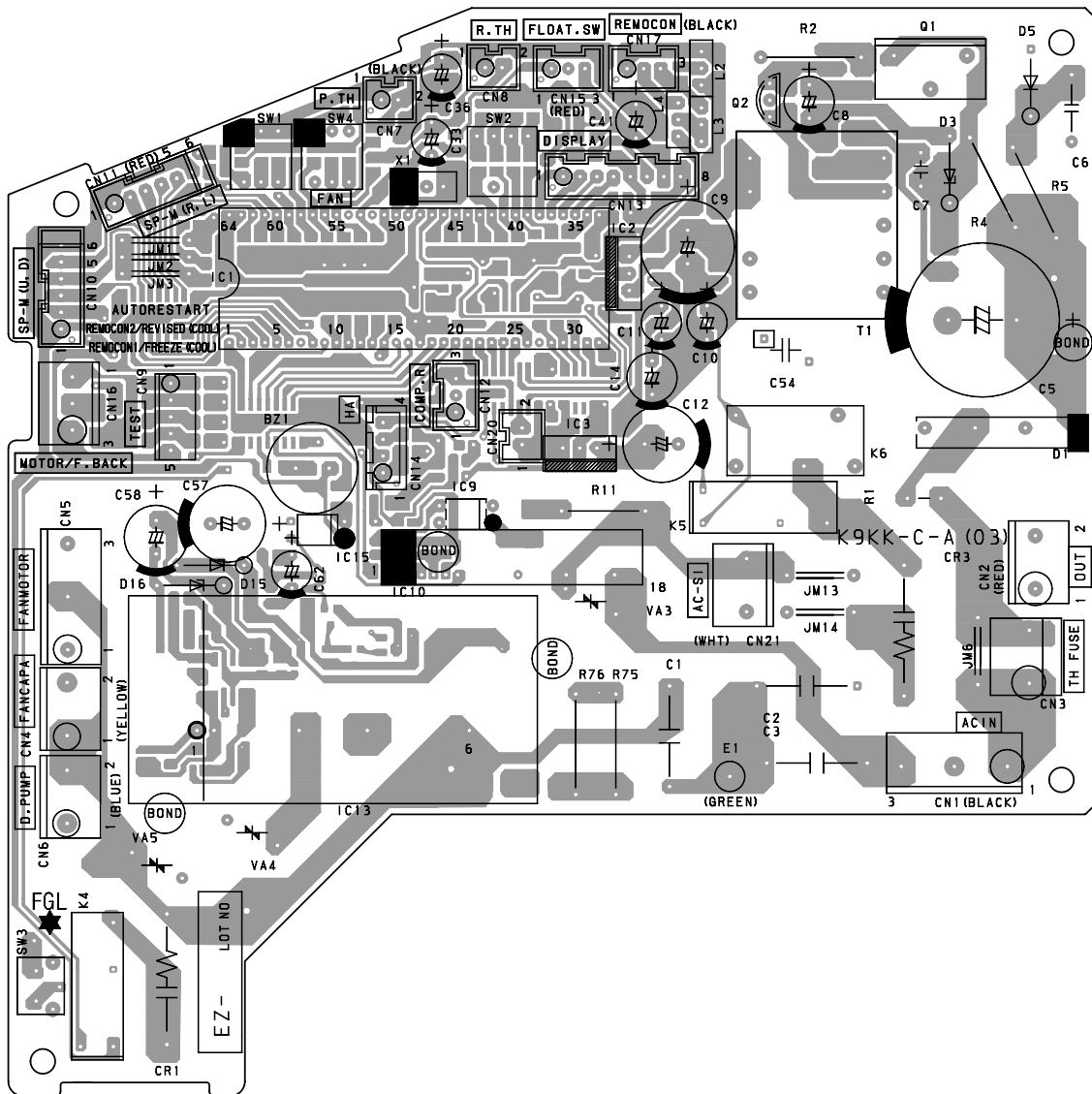

FILTER PCB ASSEMBLY

(Viewed from the component side)

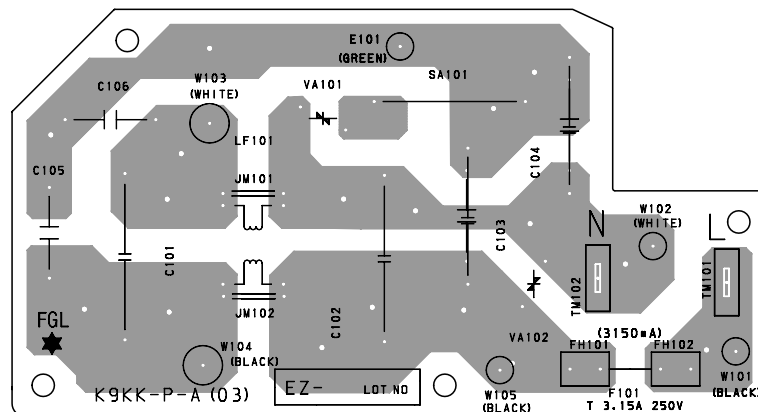

CONTROLLER PCB ASSEMBLY (MAIN PCB)

(Viewed from the solder side)

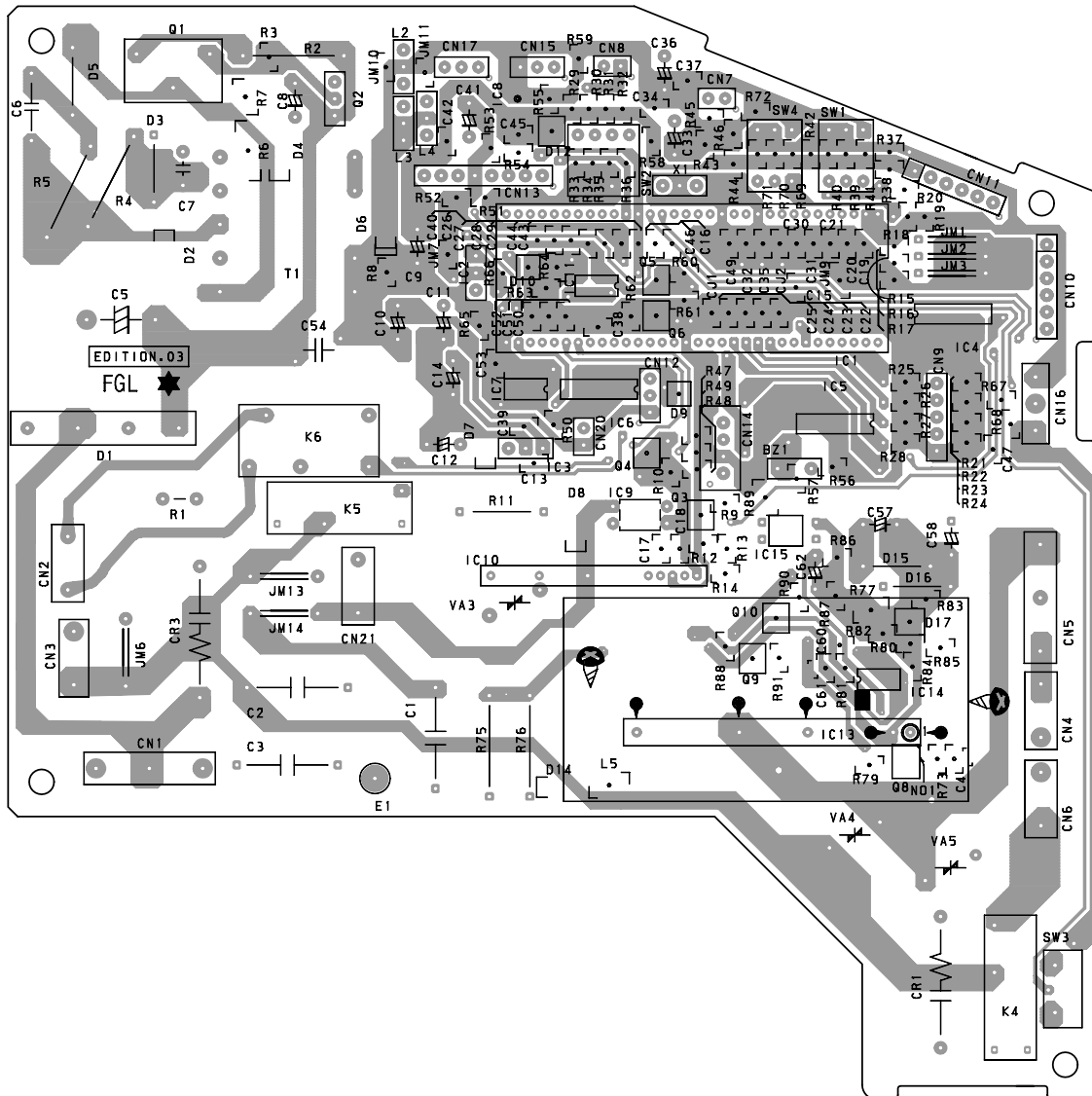

INDICATOR PCB ASSEMBLY

(Viewed from the solder side)

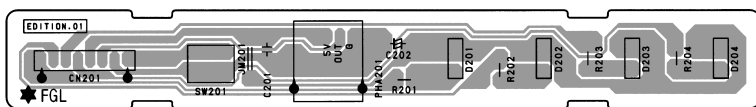

FILTER PCB ASSEMBLY

(Viewed from the solder side)

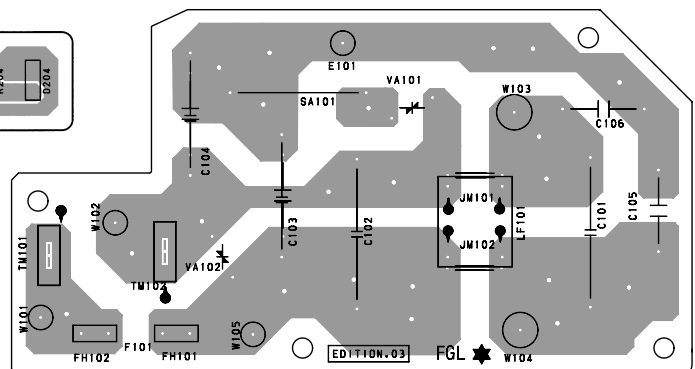

Models : RCW-25CA
RCW-30CA

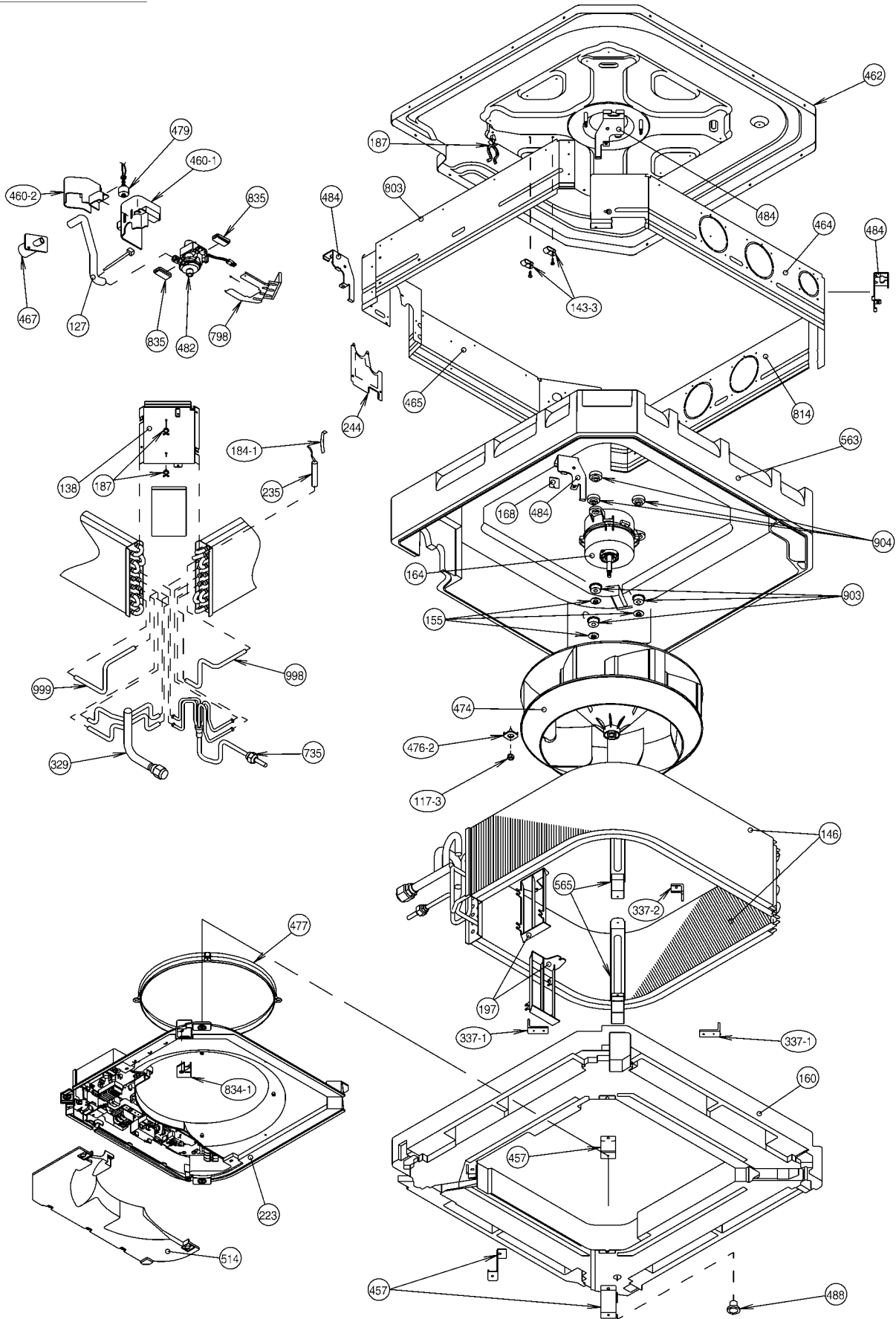

Models : RCW-25CA
RCW-30CA

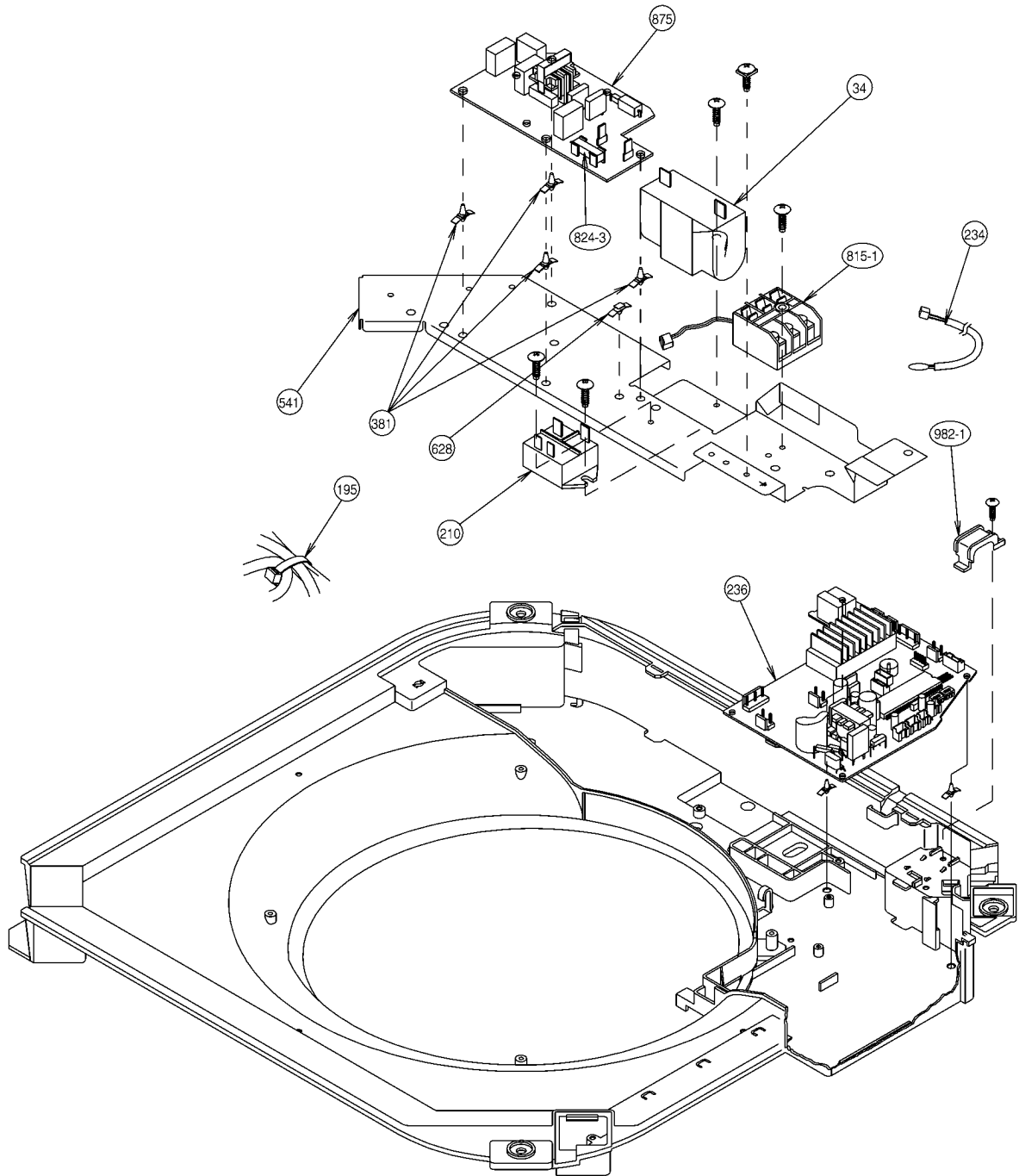

Model : RO-25A

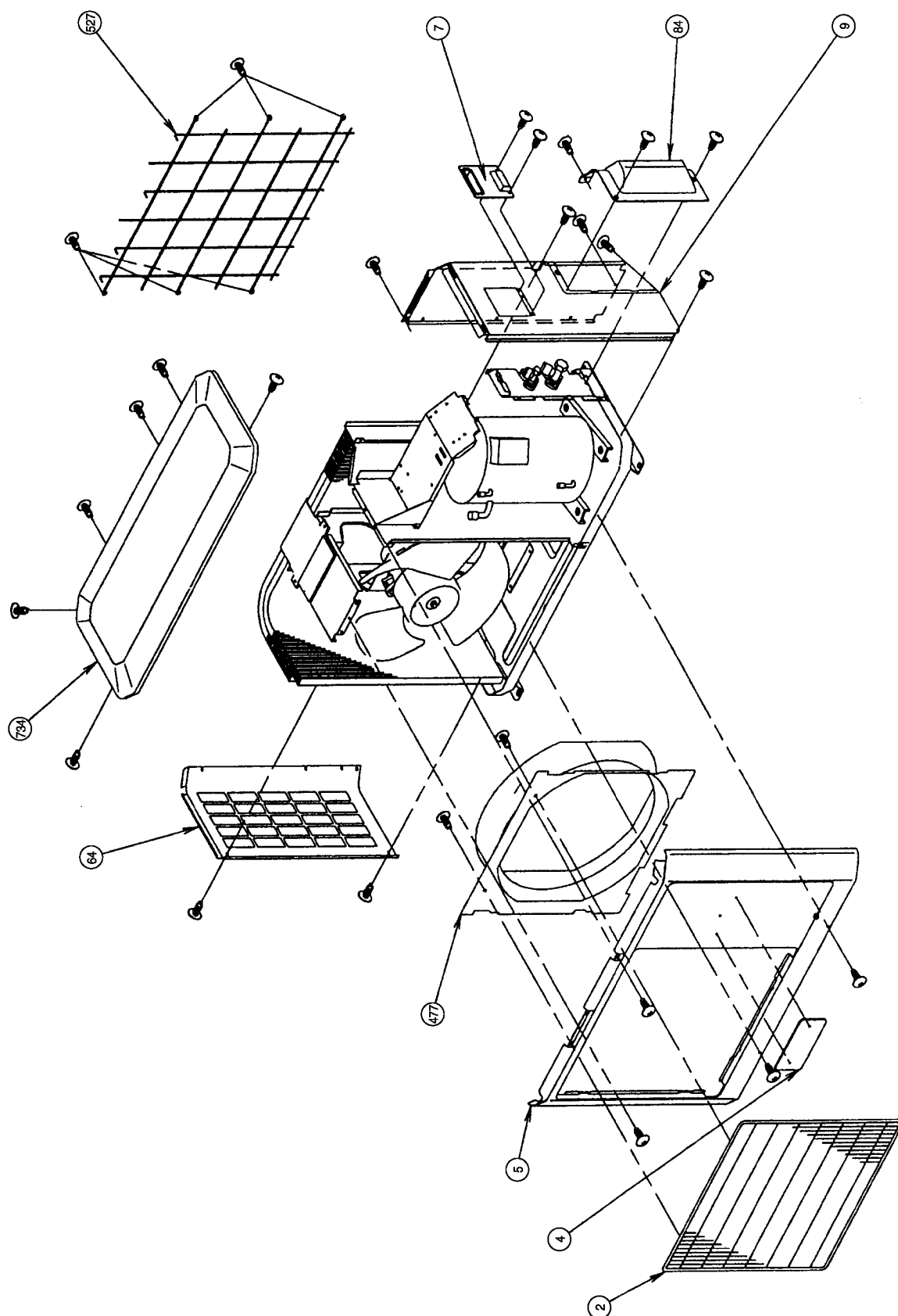

Model : RO-25A

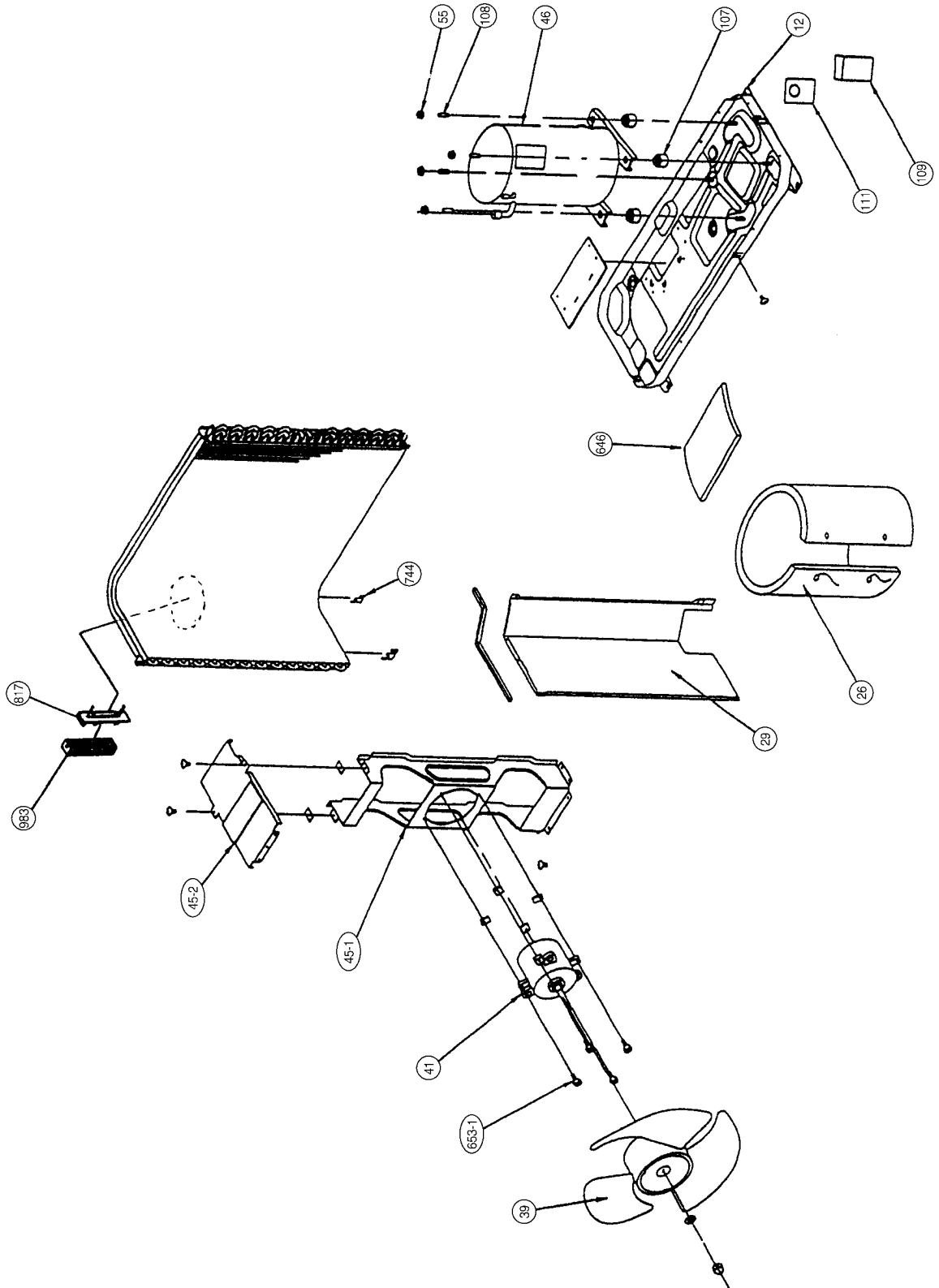

Model : RO-25A

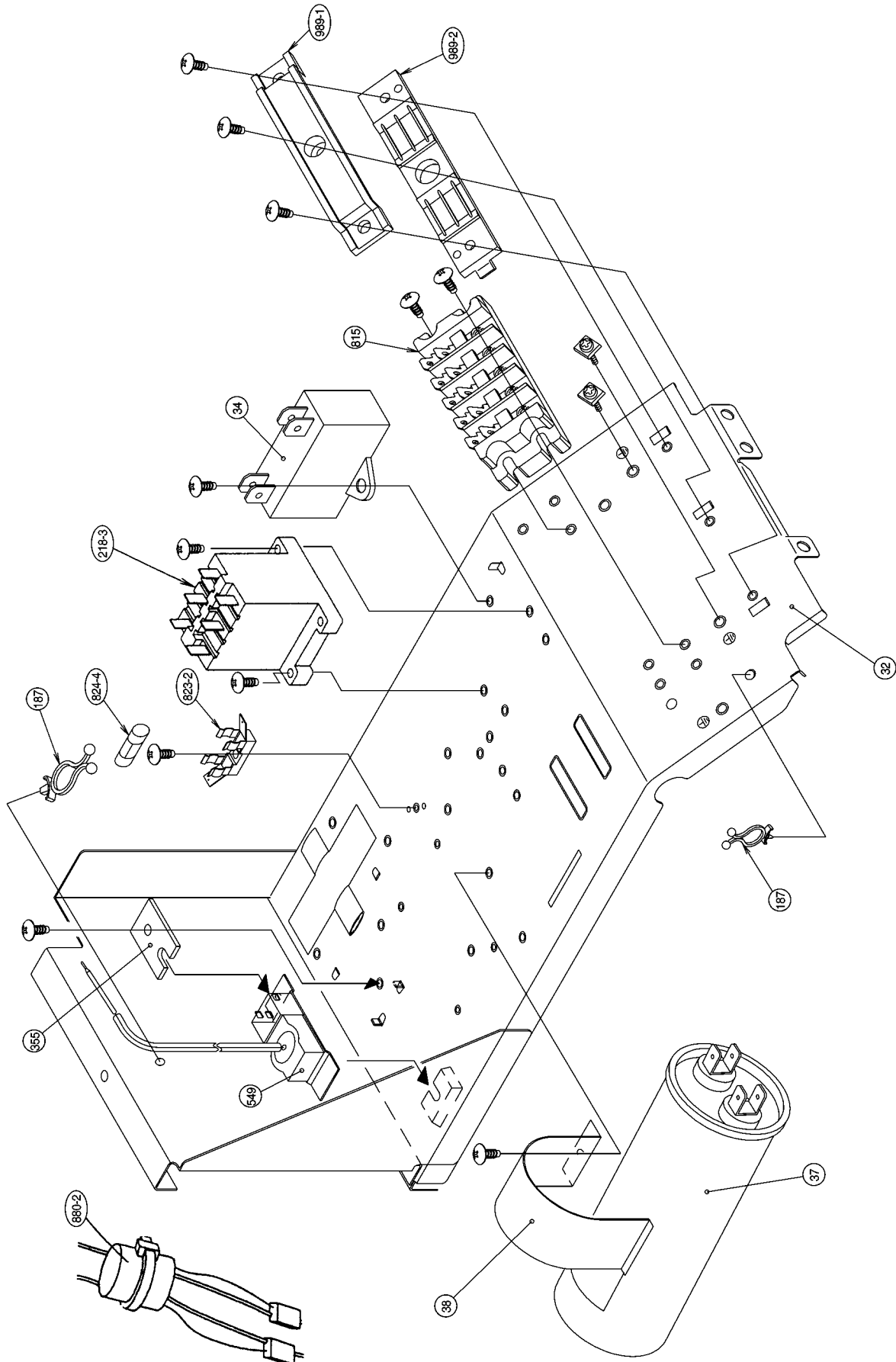

Model : RO-25A

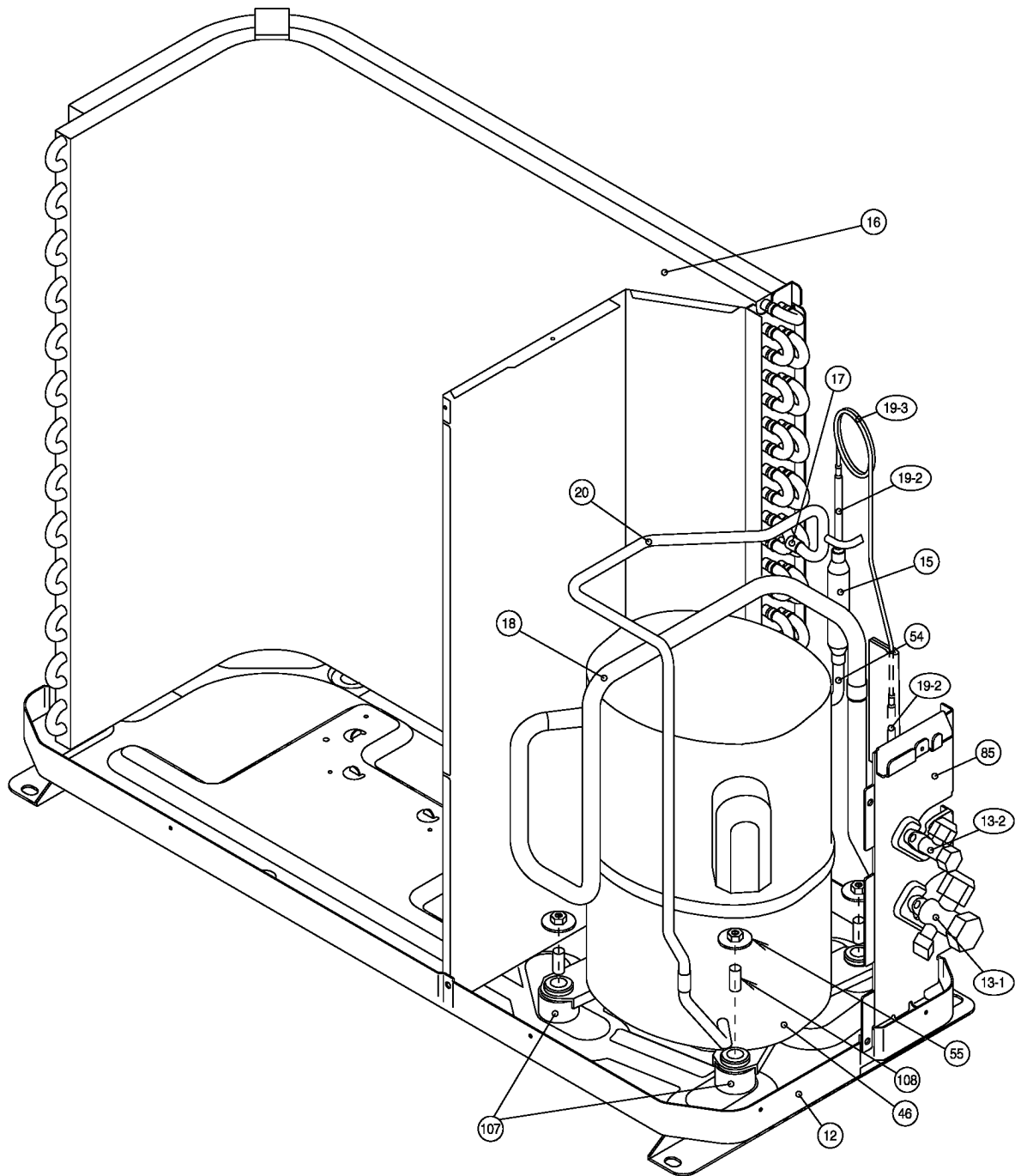

Model : RO-30A

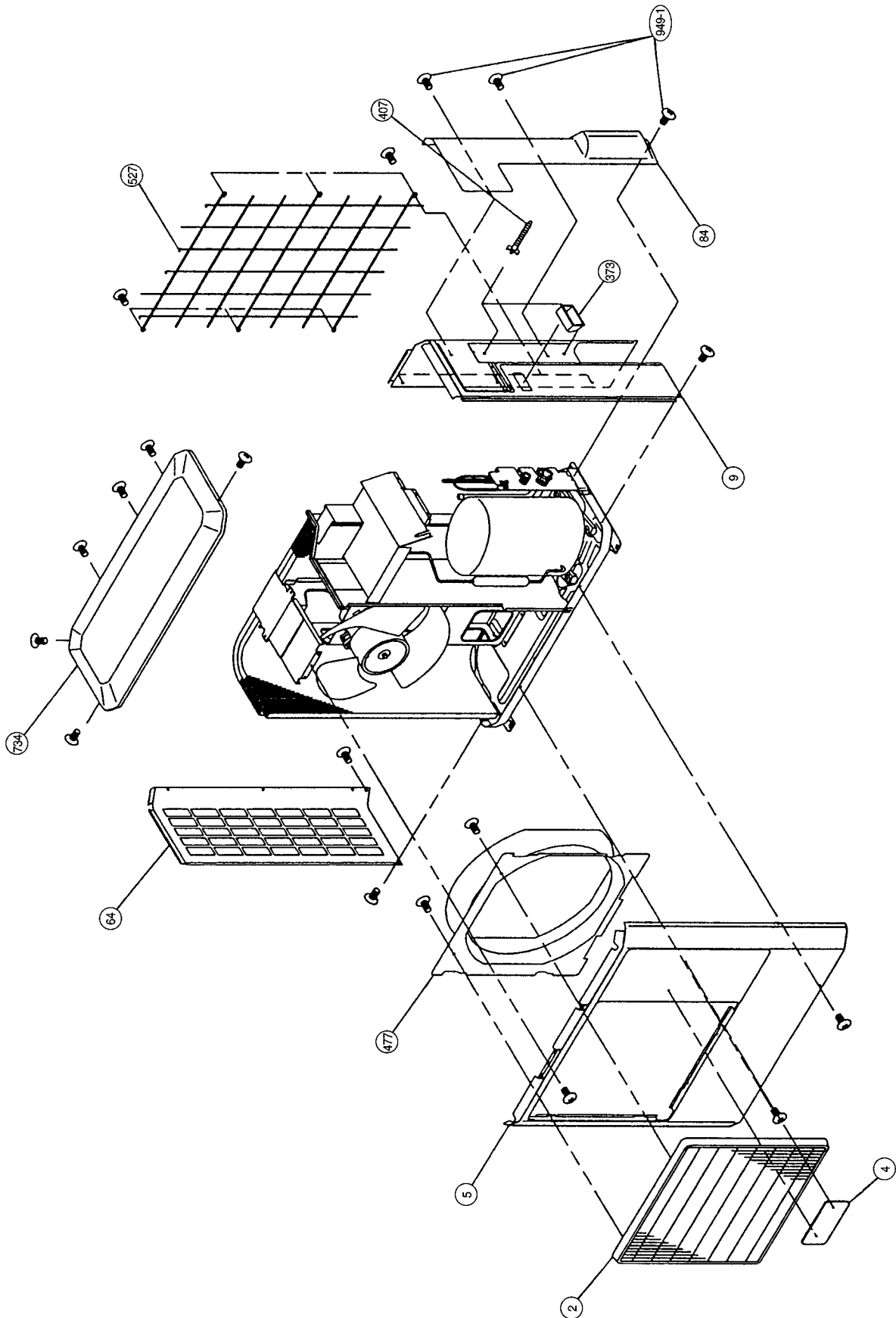

Model : RO-30A

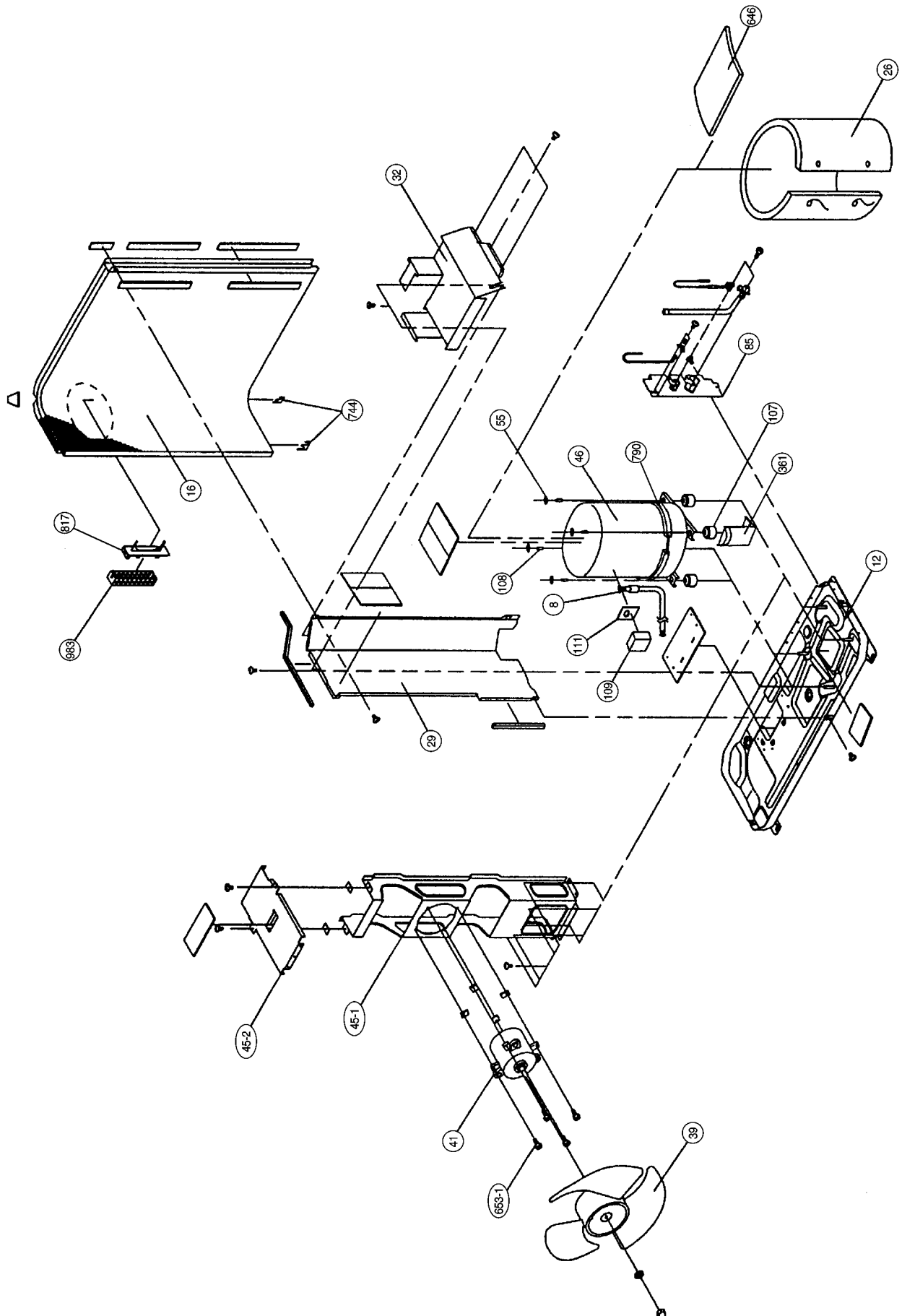

Model : RO-30A

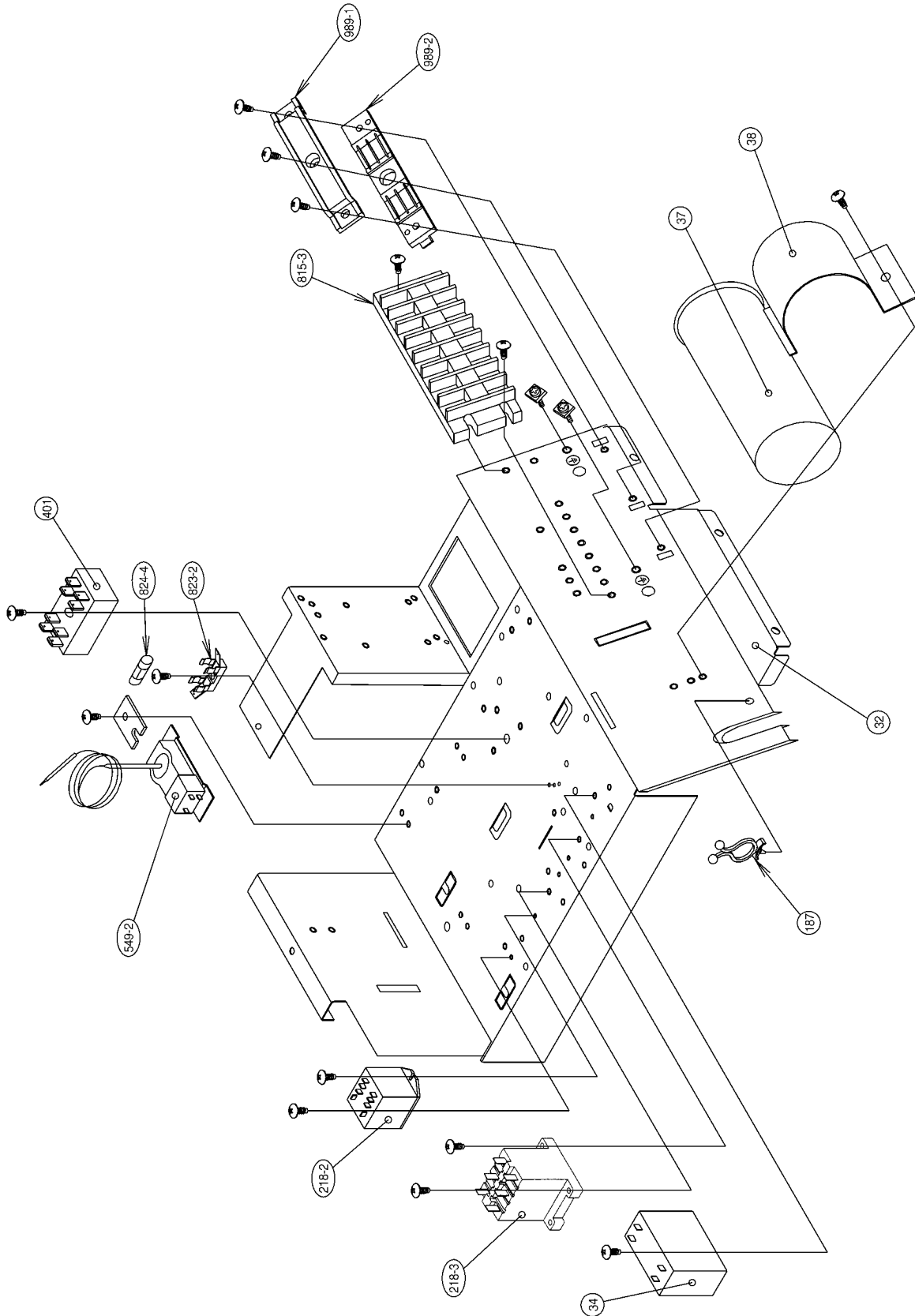

Model : RO-30A

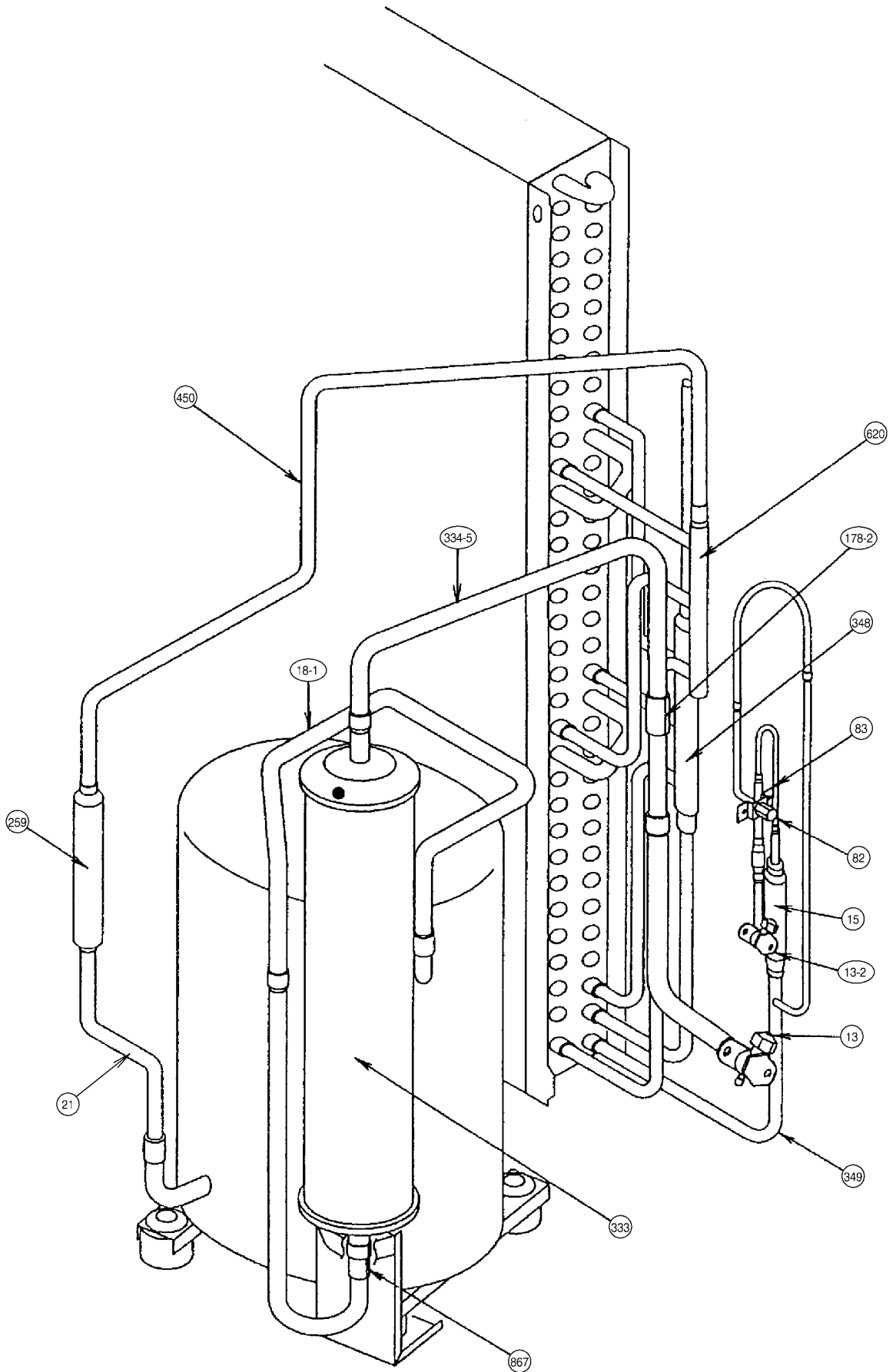

PARTS LIST

When you order parts, please make a photocopy of this page and fill the number of the parts in the "Order" column.

INDOOR UNIT

Ref. No.	Description	Part No.		Ord. Q'ty	Ref. No.	Description	Part No.		Ord. Q'ty
		RCW-25CA	RCW-30CA				RCW-25CA	RCW-30CA	
34	Capacitor (Fan Motor)	9703306068	9703306068		474	Turbo Fan Assy	9362810012	9362810012	
61	Decoration Plate	9369323003	9369323003		476-2	Special Washer	9362756006	9362756006	
71	Grille Hook Holder	9362782005	9362782005		477	Bellmouth (B)	9362774000	9362774000	
93	Filter	9362766005	9362766005		479	Float Switch	9703285004	9703285004	
117-3	Hex. Nut w/Spring Washer	301721180114	301721180114		481	Insulation (Grille) A	9362780001	9362780001	
122	Louver Support Holder	9362799003	9362799003		481-1	Insulation (Grille) B	9362781008	9362781008	
127	Drain Hose	9365074008	9365074008		482	Pump Unit	9703125010	9703125010	
138	Separate Wall	9362793001	9362793001		484	Hook	9362736008	9362736008	
143-3	Clamp NK-6N	9305657001	9305657001		487	Grille Hinge Wire	9362754002	9362754002	
146	Evaporator Assy	9365376003	9366300007		488	Drain Pan Plug	313005174654	313005174654	
155	Special Nut M6	9307615016	9307615016		514	Control Box Cover	9362763004	9362763004	
160	Drain Pan Assy	9362804004	9362804004		522	Joint Gear	9362772006	9362772006	
164	Fan Motor Assy-In	9601092018	9601092018		541	Terminal Plate	9363642001	9363642001	
168	Cabinet-E	9362735001	9362735001		542	Panel Base	9362759014	9362759014	
184-1	Thermostat Spring-A	313728262708	313728262708		543	Panel Frame Holder	9362761017	9362761017	
187	Clamp No.1219	313361271706	313361271706		544	Panel Base Holder	9362760010	9362760010	
195	Clamp SKB-100	313361275805	313361275805		545	Panel Frame	9362758017	9362758017	
197	Wind Guide Board	9363117004	9363117004		563	Insulation (Inner Box)	9362797009	9362797009	
210	Main Relay	9356781007	9356781007		565	Evaporator Holder Assy	9362802024	9362802024	
223	Control Box	9362762007	9362762007		628	Locking Spacer-B	313005446558	313005446558	
226	Motor Gear	9362764001	9362764001		690	Joint-A	9362773003	9362773003	
234	Thermistor Assy-Room	9703299025	9703299025		692	Joint Shaft	9362771009	9362771009	
235	Thermistor Assy-Pipe	9703297014	9703297014		705	Louver	9362769013	9362769013	
236	Controller PCB Assy	9704028020	9704028037		710	Intake Grille-B	9362854016	9362854016	
240	Remote Control Unit	9359913085	9359913085		735	Distributor Assy	9365353004	9365353004	
244	Pipe Cover	9362748001	9362748001		743	Remote Control Unit Holder Case	9359955016	9359955016	
329	Coupling Pipe Assy	9365354001	9365354001		777-1	Grille Hook-A	9362779012	9362779012	
337-1	Reinforcement (Eva.)-A	9362749008	9362749008		777-2	Grille Hook-B	9362778015	9362778015	
337-2	Reinforcement (Eva.)-B	9362750004	9362750004		798	Pump Hook Bracket	9362753005	9362753005	
338	Motor Holder	9362765008	9362765008		803	Cabinet-D	9362792004	9362792004	
381	Locking Spacer	313209391506	313209391506		814	Cabinet-C	9362791007	9362791007	
385	Indicator PCB Assy	9704017017	9704017017		815-1	Terminal-3P	9306489069	9306489069	
457	Reinforcement (Drain Pan)	9362757003	9362757003		824-3	Fuse	0600285210	0600285210	
460-1	Pump Cover-A	9362775007	9362775007		834-1	Wire Cover-A	9362789004	9362789004	
460-2	Pump Cover-B	9362776004	9362776004		834-2	Wire Cover-B	9362788007	9362788007	
462	Top Cover Plate Assy	9362806022	9362806022		835	Cushion Rubber (Pump)	9362777001	9362777001	
464	Cabinet-A Assy	9362807012	9362807012		847	Louver Supporter	9362770019	9362770019	
465	Cabinet-B Assy	9362808019	9362808019		858	Grille Spring	9362755009	9362755009	
467	Drain Port	9362786003	9362786003		868	Holder (PCB)	9364855004	9364855004	
469	Special Nut-B (Small)	313005446759	313005446759		875	Filter PCB Assy	9703683015	9703683015	
469-1	Special Nut-A (Large)	313005446653	313005446653		876-2	Step Motor	9360307019	9360307019	
472-1	Grille Reinforcement-A	9362738002	9362738002		903	Rubber (Vibration-proof)-A	9364891002	9364891002	
472-2	Grille Reinforcement-B	9362739009	9362739009		904	Rubber (Vibration-proof)-B	9364892009	9364892009	
472-3	Grille Reinforcement-C	9362740005	9362740005		982-1	Cord Clamp	9356857009	9356857009	
472-4	Grille Reinforcement-D	9362741002	9362741002		998	Bypass Pipe-A	9365360002	9365360002	
472-5	Grille Reinforcement-E	9362742009	9362742009		999	Bypass Pipe-B	9365361009	9365361009	

When you order parts, please make a photocopy of this page and fill the number of the parts in the "Order" column.

OUTDOOR UNIT

Ref. No.	Description	Part No.		Ord. Q'ty	Ref. No.	Description	Part No.		Ord. Q'ty
		RO-25A	RO-30A				RO-25A	RO-30A	
2	Fan Cover (Guard)	9359808015	9359808015		108	Sleeve-A (For Comp.)	313093081706	313696081700	
4	Emblem-Rear	9361328006	9361328006		109	Terminal Cover (For Comp.)	313202059600	9352456022	
5	Cabinet-A, Painted	9359797043	9359797029		111	Terminal Packing (For Comp.)	313202059807	9352456039	
7	Connector Cover	9358011010	_____		178-2	Capillary Holder Rubber	_____	313394274808	
8	Wire Assy (Shield)-D	_____	9359904021		187	Clamp No.1219	313361271706	313361271706	
9	Cabinet-B, Painted	9361323025	9359798026		218-2	Power Relay	_____	9900008011	
12	Base Assy, Painted	9359812029	9359812029		218-3	Power Relay	9704171016	9704171016	
13	3-Way Valve (5/8)	_____	9360157003		259	Muffler	_____	313755083903	
13-1	Packed Valve (5/8A)	9365096000	_____		333	Accumulator	_____	9366439004	
13-2	Packed Valve (3/8)	9360150004	9360150004		334-5	Suction Pipe-E	_____	9361052000	
15	Dryer	9368111014	9368111014		348	Outlet Pipe (Cond.) Assy	_____	9360171009	
16	Condenser Assy	9365636008	9360280015		349	Outlet Pipe-E	_____	9360174000	
17	"U" Pipe-Y	9305523009	_____		355	Switch Bracket	313986353607	_____	
18	Suction Pipe	9365610008	_____		361	Accumulator Support Assy	_____	9359843016	
18-1	Suction Pipe-A	_____	9360152008		373	Grip	_____	9352157004	
19-2	Joint Pipe (Capillary)	9365621004	_____		401	Terminal-2P	_____	9701971015	
19-3	Capillary Tube	9365622001	_____		407	Clamp (Cable) No. 1259	_____	313739340109	
20	Discharge Pipe Assy	9365618004	_____		450	Discharge Pipe-A	_____	9360166005	
21	Discharge Pipe-B	_____	9360156006		477	Bellmouth	9359809012	9359809012	
26	Compressor Cover-A	9365426005	9362501002		527	Protection Net	9359845010	9359844013	
29	Separate Wall	9359805014	9359804017		549	Thermostat-Outdoor	9352553004	_____	
32	Control Box Metal	_____	9359839019		549-2	Thermostat-Outdoor	_____	9353680006	
32	Control Box Metal-A	9361409026	_____		620	Inlet Pipe (Cond.) Assy	_____	9360167002	
34	Capacitor (Fan Motor)	9357965024	9357965024		646	Compressor Cover-B	313986355101	9353368003	
37	Running Capacitor	9704436023	9703107078		653-1	Bolt (Fan Motor Fixing)	0700156014	0700156014	
38	Capacitor Clamp	9351770013	9360610010		734	Cabinet Top Plate	9359799023	9359799023	
39	Propeller Fan	9359837015	9359837015		744	Clamp (Condenser)	313166374106	313166374106	
41	Fan Motor Assy-Out	9600832011	9600832011		790	Belt Heater	_____	9361140035	
45-1	Motor Bracket Metal	9359802013	9359801016		815	Terminal-5P	9356497021	_____	
45-2	Motor Bracket-Top Metal	9359803010	9369803010		815-3	Terminal-8P	_____	9358660119	
46	Compressor Assy	9360509017	9360613011		817	Thermostat Fixture	9352164019	9352164019	
54	Condensing Pipe	9365620007	_____		823-2	Fuse Holder	0500063024	0500063024	
55	Special Nut M8 (For Comp.)	313252257701	313252257701		824-4	Fuse	0600222529	0600222529	
64	Cabinet Left	9359840046	9359840022		867	Accumulator Holder Rubber	_____	9354022010	
82	Check Joint Assy	_____	9360762009		880-2	Network	9701020010	_____	
83	Check Joint Bracket Metal	_____	9359807018		949-1	Screw, Painted White	_____	9305648009	
84	Valve Cover	9361325012	9359817017		983	Thermostat Cover	9358274002	9358274002	
85	Valve Fixing Plate Metal	9361324015	9359806011		989-1	Cord Clamp-A	9359822011	9359822011	
107	Rubber Seat-A (For Comp.)	313093081402	313102081406		989-2	Cord Clamp-B	9359823018	9359823018	

[INDOOR UNIT]

CONTROLLER PCB ASSEMBLY (Ref. No.236)

When you order parts, please make a photocopy of this page and fill the number of the parts in the "Order" column.

Ref. No.	Description	Part No.	Ord. Q'ty	Ref. No.	Description	Part No.	Ord. Q'ty
IC1	IC uPD78014HCW-033	9704030016		R85	Res. 1/10W 3.3kohm+-1%	0200279251	
IC2	IC NJM7812FA	0100462104		R86	Res. 1/10W 39kohm+-5%	0200213156	
IC3	IC NJM7805FA	0100462081		R88	Res. 1/10W 22kohm+-1%	0200279657	
IC4-6	Xstr Array Upa2003gr	0100028041		R89	Res. 1/4W 1kohm+-5%	0200708744	
IC7	IC BR93LC46RF-E2	0100295016		R90	Res. 1/10W 47kohm+-5%	0200213170	
IC8	IC PST600CMTR	0101461120		R91	Res. 1/10W 2.2kohm+-5%	0200212821	
IC9	Photocoupler TLP621(D4)-GB	0000117074		JM9	Res. 0 ohm	0200230016	
IC13	IC G3WA-201PL	9703248016		C1,2	Cap. Plastic 0.22uF	0301052098	
IC14	IC BA10393F	0101269023		C4	Cap. Ceramic 50V 470pF	0301102649	
IC15	Photocoupler PS2561-1-VL	0000050456		C5	Cap. Elec. 450V 100uF	0300256060	
Q1	Xstr 2SC4236	0000164047		C6	Cap. Plastic 4700pF	0300269091	
Q2	Xstr 2SC1815	0000002011		C7	Cap. Plastic 50V 0.047uF	0300169339	
Q3,4	Xstr DTC124EKA	0000936033		C8	Cap. Elec. 25V 100uF	0301197560	
Q8	Xstr uPA609T	0000820035		C9	Cap. Elec. 25V 1000uF	0301196495	
Q9,10	Xstr 2SC2712	0000781053		C10,11,33,36,41	Cap. Elec. 25V 10uF	0301192312	
D1	Diode D3SB60	0000689045		C12,57	Cap. Elec. 25V 1000uF	0301158264	
D2,4,7	Diode D1FL20U	0000746519		C13,15,34,37,39,44,45,47,60	Cap. Ceramic 50V 0.1uF	0300311752	
D3	Diode MTZJ5.1B	0000852166		C14	Cap. Elec. 25V 100uF	0301192350	
D5	Diode 1SR139-600	0000353120		C16-31,38,40,42,46,49,CJ2	Cap. Ceramic 50V 0.01uF	0300311738	
D6	Diode D2FL20U	0000906500		C32,35,43,50-53	Cap. Ceramic 50V 1000pF	0300308509	
D8,14	Diode D1F60	0000208024		C54	Cap. Ceramic 0.01uF	0300209127	
D9	Diode DA226U	0000625036		C58	Cap. Elec. 25V 220uF	0301021490	
D12,17	Diode DAN202K	0000684019		C61	Cap. Ceramic 50V 4700pF	0300308585	
D15	Diode MTZJ11B	0000853095		C62	Cap. Elec. 25V 22uF	0301192329	
D16	Diode MTZJ7.5B	0000852012		K4	Relay G5N-1A	9701566013	
R1	Res. Cement 5W 3.3ohm+-10%	0200153148		T1	Switching Transformer ETS28AS118AH	9702727017	
R2	Res. Metal Oxide 2W 1.5ohm+-5%	0201107119		SW1,4	Slide Switch DSS803	9701392018	
R3	Res. 1/10W 100ohm+-5%	0200212500		SW2	Rotary Switch DRS4016-5	9701694013	
R4	Res. Metal Film 2W 330kohm+-5%	0200357133		CR1	GR Absorber RPEL-121204-C	9701125012	
R5	Res. Metal Oxide 2W 62kohm+-5%	0201107997		VA4,5	Varistor TNR10V471K	0000361224	
R6	Res. 1/2W 100ohm+-5%	0200731506		E1	Wire w/Terminal GRN L=150	9702313029	
R7	Res. 1/4W 330ohm+-5%	0200708621		L5	High Frequency Coil LQH3C470K34T1	0400201298	
R8,10,13,15-17,37,39,48,50,52,53,55,59,68,70	Res. 1/10W 10kohm+-5%	0201011010		JM2,3	Wire 0.6dia. L=10mm	9700025016	
R9,47	Res. 1/10W 390ohm+-5%	0200212647		X1	Ceramic Resonator EF0EC8384T4	9701261017	
R11	Res. Metal Oxide 1W 56kohm+-5%	0201106662		BZ1	Buzzer PKM13EPY-4000-TF01	9701298013	
R12,18-20,25-28,33-36,38,42,44,46,49,51,57,58,67,69,73	Res. 1/10W 1kohm+-5%	0200212746		CN1	Plug, PCB 5-1123724-2	0501321574	
R40,41,71,72,79	Res. 1/10W 4.7kohm+-5%	0200212906		CN3	Plug, PCB 53406-9910	0500951048	
R43	Res. 1/10W 10kohm+-1%	0200279497		CN4	Plug, PCB 2-1123724-2	0501321529	
R45	Res. 1/10W 49.9kohm+-1%	0200279824		CN5	Plug, PCB 1-1123724-3	0501321451	
R54	Res. 1/10W 47ohm+-5%	0200212425		CN6	Plug, PCB 3-1123724-2	0501321536	
R56,CJ1	Res. 1/10W 0 ohm	0200212012		CN7	Plug, PCB B2B-XAKK-1-A	0501045227	
R75,76	Res. Metal Oxide 2W 22kohm+-5%	0201107614		CN8	Plug, PCB B2B-XASK-1-A	0501045012	
R77	Res. 1/4W 470ohm+-5%	0200708669		CN9	Plug, PCB B5P-SHF-1AA	0500006069	
R80	Res. 1/10W 33ohm+-5%	0200212388		CN10	Plug, PCB B5B-XASK-1-A	0501045043	
R81,87	Res. 1/10W 33kohm+-1%	0200279732		CN12	Plug, PCB B3B-XASK-1-A	0501045029	
R82	Res. 1/10W 5.6kohm+-1%	0200279374		CN13	Plug, PCB B8B-XASK-1-A	0501045074	
R83	Res. 1/10W 3.9kohm+-1%	0200279299		CN14	Plug, PCB B4B-XH-AM	0500005314	
R84	Res. 1/10W 15kohm+-1%	0200279572		CN15	Plug, PCB B3B-XARK-1-A	0501045319	
				CN16	Plug, PCB 1-1123723-3	0501321079	
				CN21	Plug, PCB 1-1123724-2	0501321512	

When you order parts, please make a photocopy of this page and fill the number of the parts in the "Order" column.

FILTER PCB ASSEMBLY (Ref. No.875)







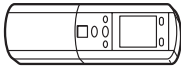

Ref. No.	Description	Part No.	Ord. Q'ty	Ref. No.	Description	Part No.	Ord. Q'ty
VA101,102	Varistor TNR10V471K	0000361224		C101,102	Cap. Plastic 1uF	0300304136	
SA101	Arrester DSA-362MA-05	0600168032		C105,106	Cap. Plastic 0.022uF	0301052098	
TM101,102	Plug Contact 86028	0500536016		W102,103	Wire #18 2P	9703251030	
LF101	EMI Filter ELF18D650C	0400410294		W103,104	Wire #18 2P	9703251023	
F101	Fuse 2183.15	0600285210		E101	Wire w/Terminal L=100 GRN	9702313012	
FH1,2	Fuse Holder PFC5000-0502	0500158072					

INDICATOR PCB ASSEMBLY (Ref. No.385)

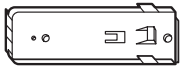

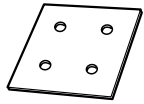

Ref. No.	Description	Part No.	Ord. Q'ty	Ref. No.	Description	Part No.	Ord. Q'ty
PHA201	Remote Control Amplifier SBX1810-22	0101525129		C201	Cap. Ceramic 50V 0.1uF	0300988251	
D201	Diode SLR-325VC RED	0000813259		C202	Cap. Elec. 25V 10uF	0300478288	
D202	Diode SLR-325MC GRN	0000813242		SW201	Push Switch EVQ-PAG-04K	9700450016	
D203	Diode SLR-325DC ORG	0000813235		CN201	Wire w/Connector L=300	9702264017	
R201-203	Res. Carbon 1/4W 330ohm+-5%	0201038659		JM201	Wire 0.6dia. L=7.5	9701076017	

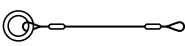
STANDARD ACCESSORIES

INDOOR UNIT ACCESSORIES

Name and Shape	Q'ty	Application	Parts No.
Remote control unit 	1	Use for air conditioner operation	9359913047
Battery (pen light) 	4	For remote control unit	0600185534
Remote control unit holder 	1	For mounting the remote control unit	9359955016
Special nut A (large flange) 	4	For installing indoor unit	313005446653
Special nut B (small flange) 	4	For installing indoor unit	313005446759
Coupler heat insulator 	2	For indoor side pipe joint	9350716029 } 9352766015 } 1 each
Template 	1	For ceiling hole cutting	9363173000
Tapping screw (ø3 x 12) 	3	For remote control unit holder installation	301141533125
Blower cover insulation 	2	For discharged air	9363265002
Hook wire 	2	For installing intake grille	9363168006

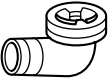
OUTDOOR UNIT ACCESSORIES

Name and Shape	Q'ty	Application	Parts No.
Hexagon wrench 	1	For opening the refrigerant valve on the outdoor unit	9351228019
Cable clip 	2	For power cord binding	313739340109
Tapping screw (painted) 	1	For installing valve cover	9305648009
Drain pipe 	1	For outdoor unit drain piping work [Heat & Cool (Reverse cycle) model only]	9303029015
Drain cap 	2		313166024302



MANUFACTURER :

Fuji Denki Sosetsu Co., Ltd.

Tokyo, Japan

0203J1975

March 2002 Printed in Japan



Большая библиотека технической документации

<https://splitsystema48.ru/instrukcii-po-ekspluatácii-kondicionerov.html>

каталоги, инструкции, сервисные мануалы, схемы.